

A Case Study on Evaluating Manual and Automated Heat Sink Assembly using FEA and Testing

Michael Randy Sumalinog
AEG-Asia, Flextronics Manufacturing Co.
Guangdong, Zhuhai, China

Jesus Tan, Murad Kurwa
AEG, Flextronics International Inc.
Milpitas, CA, USA

Abstract

Proper assembly of components is critical in the manufacturing industry as it affects functionality and reliability. In a heat sink assembly, a detailed manual process is often utilized. However, an automated fixture is used whenever applicable. This paper will illustrate the use of strain gauge testing and Finite Element Analysis (FEA) as a simulation tool to evaluate and optimize the heat sink assembly process by manual and automated methods.

Several PCBAs in the production line were subjected to the manual and automated assembly process. Strain gauge testing was performed and FEA models were built and run. Results were compared with the goal of improving the FEA model. The updated FEA model will be used in simulating different conditions in assembly. Proposed improvement solutions to some issues can also be verified through FEA.

Key words: FEA, Simulation, Heat Sink, Strain Gauge, Automation

1. Introduction

As Ball Grid Array (BGA) package sizes continually decreased, printed circuit board failures due to over-flexure during various assembly and test processes has been an increasing concern in the electronics industry. Board flexure control using strain gauge testing has been proven to be an effective method in analyzing different assembly processes. Strain gauges are devices whose resistance changes under the application of force or strain [1]. In a heat sink assembly process, an automated fixture is ideal but may not always be readily available. As such, production lines had utilized operators to do the manual work. Strain gauge measurements were done to evaluate both manual and automated assembly.

A Finite Element Analysis (FEA) assembly model was generated to assess the strain and compare with experimental data. Several iterations were made and adjusted with the goal of optimizing the FEA model. The model was used in evaluating board strain at different conditions, such as moving the BGAs at another location.

2. Strain Gauge Testing

Several PCBAs were assembled and tested. Four straight fin heat sinks are placed on top of four BGAs at different locations on the board and assembled with push pins. In a manual set-up, the operator uses a handheld fixture (Fig. 1) with two protruding metal rods designed to press the push pins into place on the board. The operator repeats this step four times until all the heat sinks are assembled into the board. During this process, strain gauges were placed to monitor board flexure. The strain gauge testing was conducted per IPC/JEDEC-9704 guidelines. Gauges were placed on all four corners of each BGA, with the center located at the intersection of lines offset from the package edge at about 3.6 mm [2].

Strain gauge testing was also done using the automated fixture. The board is placed into position on the fixture. A pneumatic press is activated with eight metal rods forcing down the push pins in place at the same time (Fig. 2).

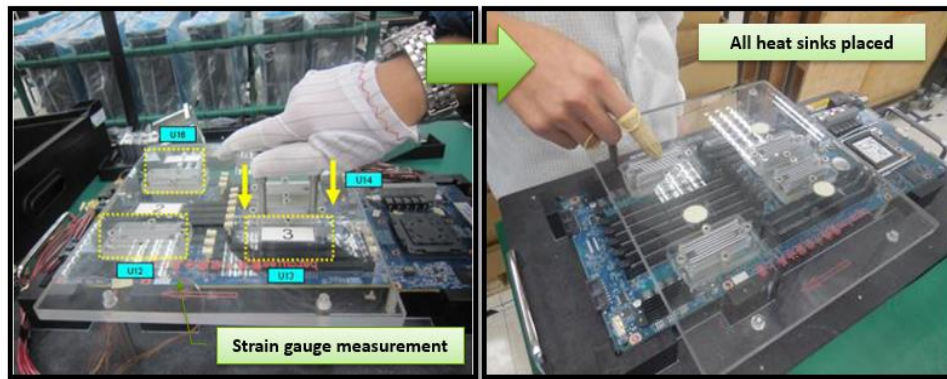

Figure 1. Strain gauge on manual assembly set-up

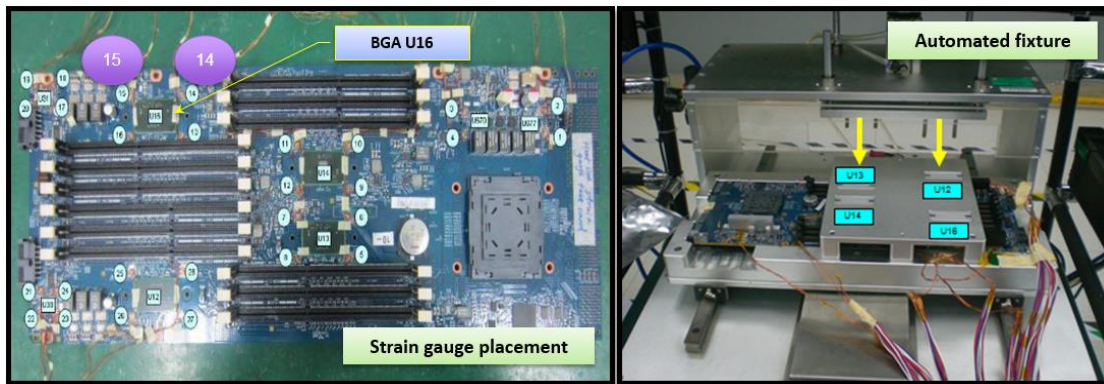

Figure 2. Strain gauge on automated assembly

3. FEA Model

The PCBA was modeled as shown in Fig. 3. Symmetry boundary condition is utilized in some PCB edges to reduce calculation time. The support is constrained in all six degrees of freedom. After several iterations, it was determined that an imposed displacement can be applied on the push pins to enhance behavior by avoiding fluctuations thereby representing reality [3]. Since the numerical results will be compared to experimental data, specific nodes were simulated in the same place where the strain gauges were positioned in actual testing, which is about an intersection of lines at 3.6 mm offset from the package edge.

Many factors affect board flexure, which include component placement. The optimized FEA model will be used in analyzing some cases in evaluating the BGA location for improvement.

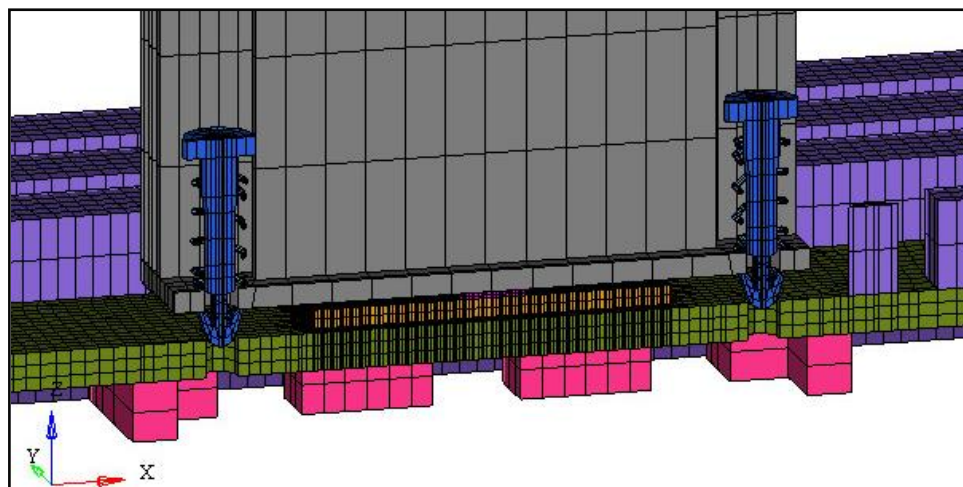

Figure 3. FEA model

Material properties used in the simulation are listed in Table 1. For the PCB, assumed core material is FR4 with a conservative modulus of elasticity.

Table 1. Material properties for FEA

Material	Type	Young's Modulus (MPa)	Poisson's Ratio
PCB	FR4	15,000	0.14
Solder	SAC	45,000	0.35
Plastic	Nylon	3,500	0.4
Substrate	Ceramic	22,000	0.25

4. Results and Comparison

Strain Gauge Analysis

The maximum principal strain for the manual assembly is about 283 $\mu\epsilon$ located at sensor 15 (near BGA U16). For the automated assembly, the maximum principal strain is slightly higher at 339 $\mu\epsilon$ located at sensor 14 (also near BGA U16). Both values are within the acceptable level of IPC/JEDEC-9704 guidelines. Looking at the graph in Fig. 4, the strain fluctuates until a peak strain is reached. As measured by a force gauge, the operator applies a varying force during manual assembly. This force increases slowly as the operator adjusts to the push pins snapping to the board and releases when assembled. This process would account for the irregular strain graph as observed. The process is different for the automated assembly. The process is different for the automated assembly. Force is applied in a faster and constant rate. The fixture then stops for a few seconds before lifting up the push metal rods. This results to a more stable strain graph as shown in Fig. 5. The differences in the strain rate graph is also evident in Fig. 6.

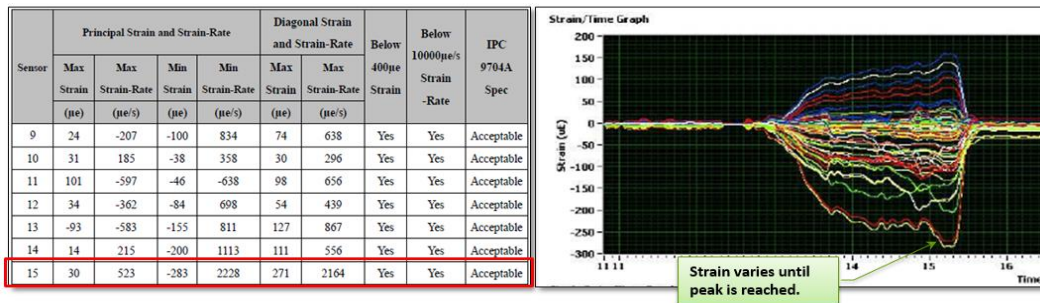

Figure 4. Max. Strain & Graph of Manual Assembly

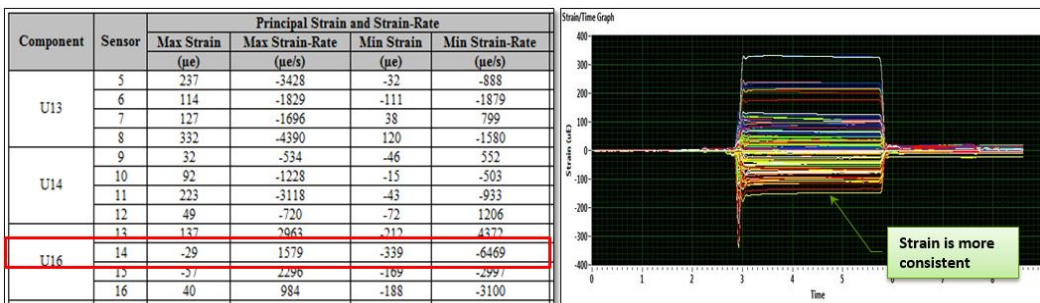

Figure 5. Max. Strain & Graph of Automated Assembly

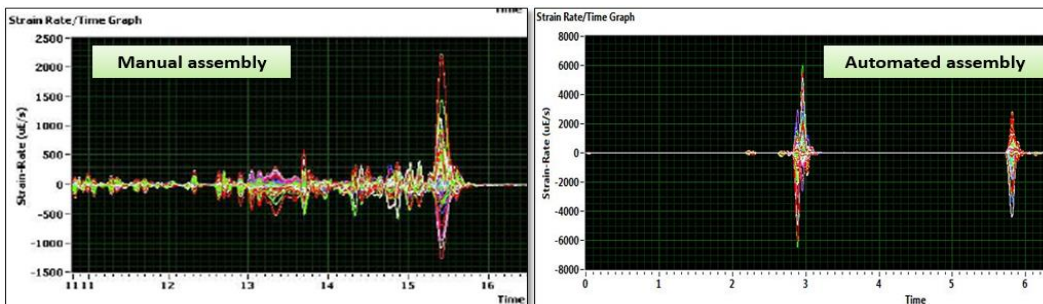

Figure 6. Strain Rate Graph (Manual & Automated)

FEA (Manual Assembly Analysis)

Several iterations of the analysis were conducted to approximate the manual assembly process. As shown in Fig. 7, there are some differences in the strain results when experimental data is compared to simulation for the manual process. Varying factors can cause this such as actual material properties, operator strength, strain gauge misplacement, or pin dimensions. However, the objective is to establish a trend in the finite element model. In this case, both lines increased until a peak strain is noted at the end of the process.

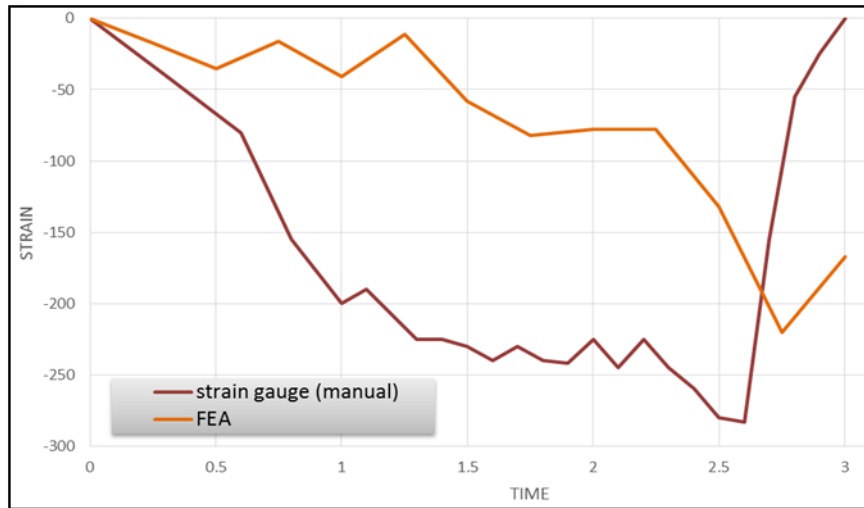

Figure 7. Max. Strain Graph (comparison for manual process)

The predicted maximum principal strain plot is shown in Fig. 8. The yellow arrow points to the approximate location of sensor 15 in the strain gauge testing, wherein strain values are higher. Typical in a press-in process, the push pin develops plastic deformation in the snap-fit features. The resulting contact forces generate the strain on the board. For the manual process, highest strain is predicted when the push pin is about to exit the PCB hole.

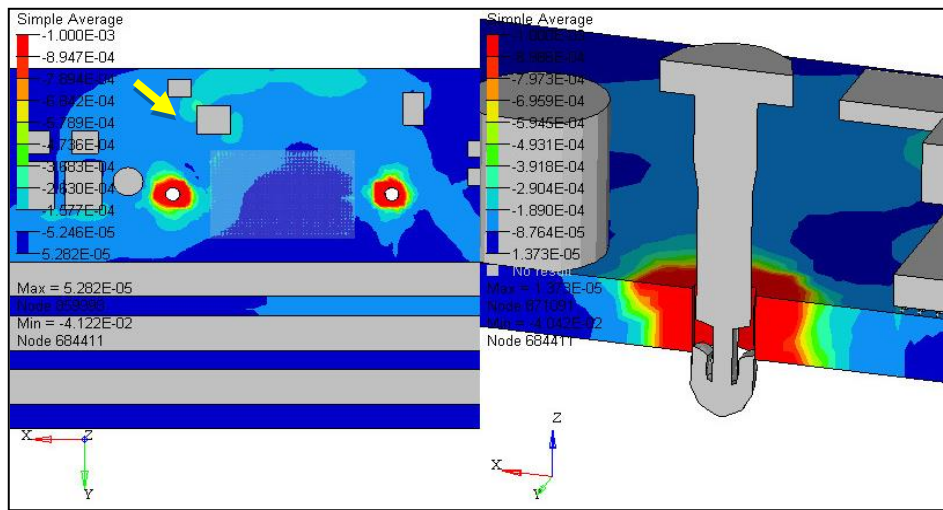

Figure 8. Max. Principal Strain (manual)

FEA (Automated Assembly Analysis)

Several iterations of the analysis were conducted to approximate the automated assembly process. As shown in Fig. 9, the graph indicates an early peak strain and decreases into a consistent value. Both the experimental and simulation graph lines show similar trends. For the automated process, the push pin is assembled to the board at a faster rate. Strain is stable when the push metal rods maintain maximum displacement for a few seconds.

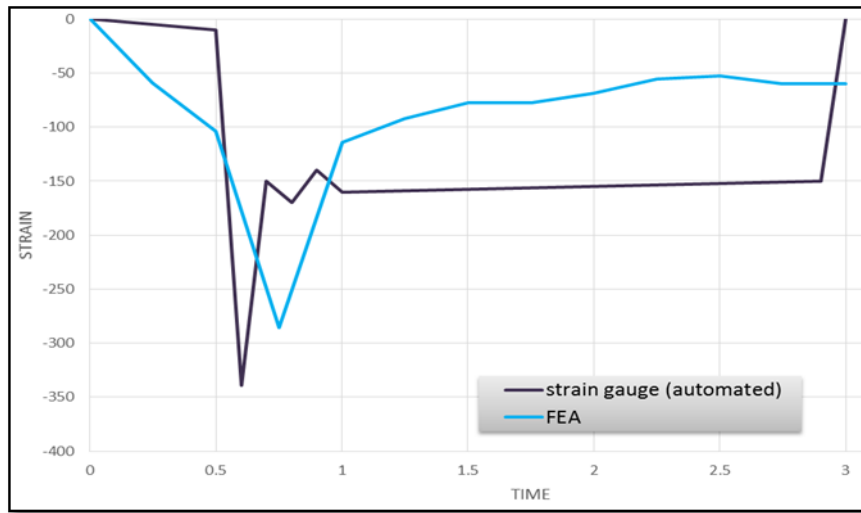

Figure 9. Max. Strain Graph (comparison for automated process)

The predicted maximum principal strain plot is shown in Fig. 10. The yellow arrow points to the approximate location of sensor 14 in the strain gauge testing, wherein strain values are higher. Similar to the manual process, the highest strain is predicted when the push pin is about to exit the PCB hole. As the pin is pushed deeper in the PCB hole, the contact area and force increases leading to the high developed strain.

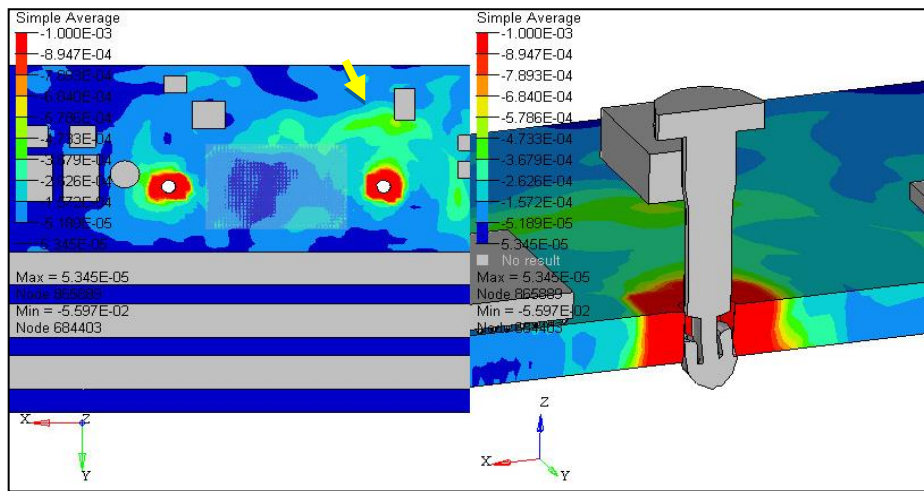

Figure 10. Max. Principal Strain (automated)

FEA (Impact of BGA Location)

For this analysis, the FE model for the automated process assembly is used for reference. The original design is referred to as Case 1. For Case 2, the BGA was moved in the Y axis (vertical) 1 mm away from the board edge. In Case 3, the BGA was moved in the -X axis (horizontal) direction by 1 mm. As shown in Fig. 10, a significant decrease in strain is observed in Case 2 while in Case 3, there was a slight increase in the predicted maximum principal strain.

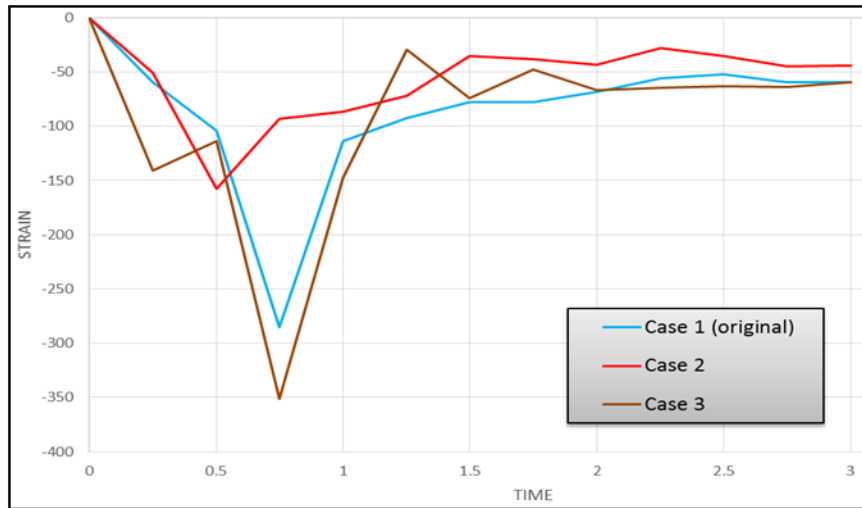

Figure 11. Max. Strain Graph (BGA location change)

Summary

The finite element models for FEA of a heat sink assembly by manual and automated processes have been presented in this paper. Based on results, automated assembly is preferred than the manual assembly process. The results of the analysis were compared to experimental data gathered through strain gauge testing. After several iterations, the differences between experimental and numerical results were reduced and trends were noted to achieve optimized FE models. These FE models can be used to perform other studies to improve strain values and avoid damaging board flexure. One such factor is the location of the BGAs on the printed circuit board.

Further studies can help improve the FE model. Actual testing for material properties can be performed. Other factors affecting BGAs can also be included in a DOE matrix.

Acknowledgement

The authors gratefully acknowledge the support of Flextronics B11 production team, especially for Andrew Qi, AEG-Asia RTC Arnel Camacho, and AEG-Asia DFX manager GP Li.

References

- [1] Haresh Khemani, "What are strain gauges and how they work?".
- [2] IPC/JEDEC-9704: Printed Wiring Board Strain Gauge Test Guideline, 2005.
- [3] Altair: RADIOSS solver manual.



A Case Study on Evaluating Manual and Automated Heat Sink Assembly using FEA and Testing

Michael Sumalinog, Jesus Tan, Murad Kurwa
Flextronics



Outline

- Introduction
- Strain Gauge Testing
- FEA model
- Results & Comparison
- Summary



Introduction

- Board flexure control using strain gauge testing has been proven to be an effective method in analyzing different assembly processes.
- In a heat sink assembly process, Strain gauge measurements were done to evaluate both manual and automated assembly.
- A Finite Element Analysis (FEA) assembly model was generated to assess the strain and compare with experimental data.



Strain Gauge Testing

- Strain gauges are devices whose resistance changes under the application of force or strain. Strain gauge testing was conducted per IPC/JEDEC-9704 guidelines.
- In a manual set-up, the operator uses a handheld fixture with two protruding metal rods designed to press the push pins into place on the board.

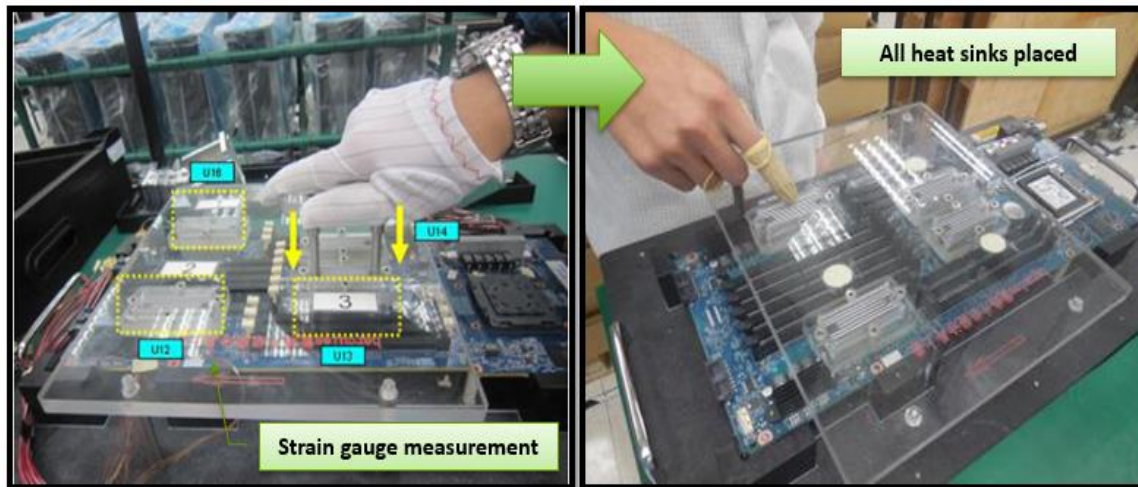



Strain Gauge Testing

- For automated process, the board is placed into position on the fixture. A pneumatic press is activated with eight metal rods forcing down the push pins in place at the same time.
- Gauges were placed on all four corners of each BGA, with the center located at the intersection of lines offset from the package edge at about 3.6 mm.

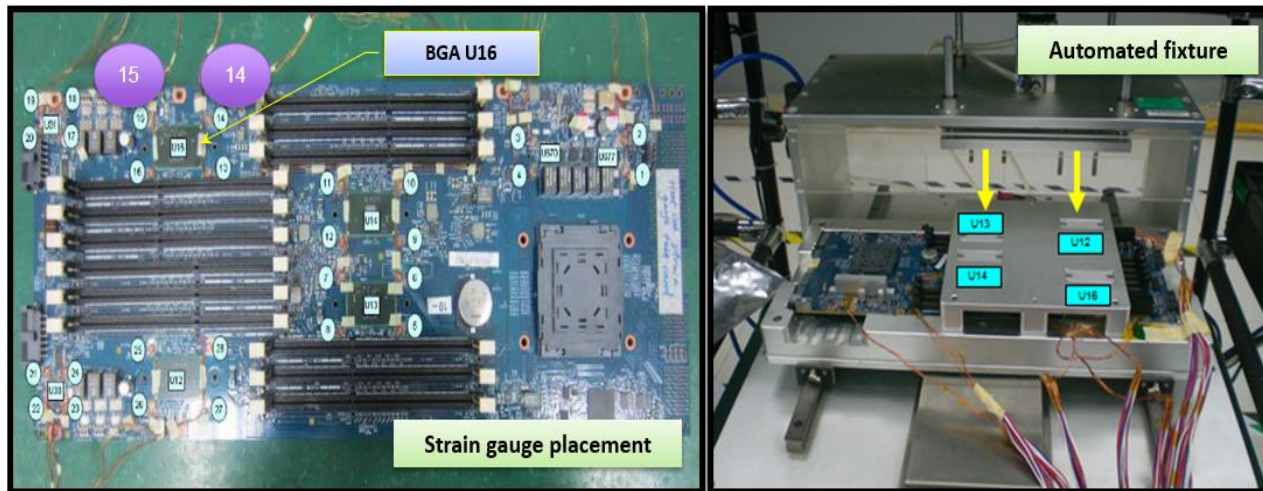



FEA Model

- Symmetry boundary condition on some PCB edges
- Support is constrained.
- After several iterations, it was determined that an imposed displacement can be applied on the push pins to enhance behavior.
- Specific nodes were simulated in the same place where strain gauges were positioned in actual testing.

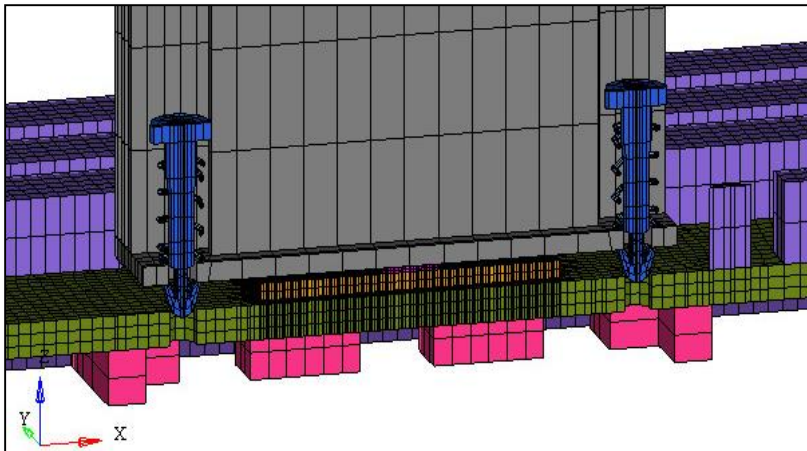

Material	Type	Young's Modulus (MPa)	Poisson's Ratio
PCB	FR4	15,000	0.14
Solder	SAC	45,000	0.35
Plastic	Nylon	3,500	0.4
Substrate	Ceramic	22,000	0.25



Results (Strain Gauge-Manual Assembly)

- Maximum principal strain for the manual assembly is about 283 $\mu\epsilon$ located at sensor 15 (near BGA U16).
- The strain fluctuates until a peak strain is reached near the end.
- As measured by a force gauge, the operator applies a varying force during manual assembly. The force increases slowly as the operator adjusts to the push pins snapping to the board and releases when assembled.

Sensor	Principal Strain and Strain-Rate				Diagonal Strain and Strain-Rate		Below 400 $\mu\epsilon$ Strain	Below 10000 $\mu\epsilon/s$ Strain-Rate	IPC 9704A Spec
	Max Strain	Max Strain-Rate	Min Strain	Min Strain-Rate	Max Strain	Max Strain-Rate			
	($\mu\epsilon$)	($\mu\epsilon/s$)	($\mu\epsilon$)	($\mu\epsilon/s$)	($\mu\epsilon$)	($\mu\epsilon/s$)			
9	24	-207	-100	834	74	638	Yes	Yes	Acceptable
10	31	185	-38	358	30	296	Yes	Yes	Acceptable
11	101	-597	-46	-638	98	656	Yes	Yes	Acceptable
12	34	-362	-84	698	54	439	Yes	Yes	Acceptable
13	-93	-583	-155	811	127	867	Yes	Yes	Acceptable
14	14	215	-200	1113	111	556	Yes	Yes	Acceptable
15	30	523	-283	2228	271	2164	Yes	Yes	Acceptable

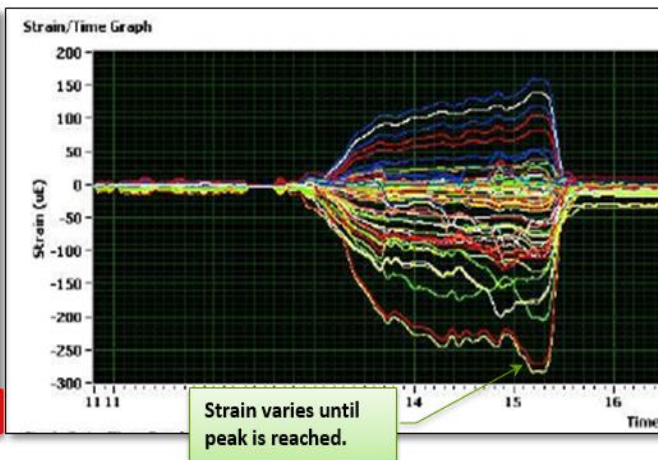



Results (Strain Gauge-Automated Assembly)

- Force is applied in a faster and constant rate.
- The fixture then stops for a few seconds before lifting up the push metal rods back to initial position.
- This results to a more stable strain graph.

Component	Sensor	Principal Strain and Strain-Rate			
		Max Strain ($\mu\epsilon$)	Max Strain-Rate ($\mu\epsilon/s$)	Min Strain ($\mu\epsilon$)	Min Strain-Rate ($\mu\epsilon/s$)
U13	5	237	-3428	-32	-888
	6	114	-1829	-111	-1879
	7	127	-1696	38	799
	8	332	-4390	120	-1580
U14	9	32	-534	-46	552
	10	92	-1228	-15	-503
	11	223	-3118	-43	-933
	12	49	-720	-72	1206
	13	137	2963	212	4372
U16	14	-29	1579	-339	-6469
	15	-57	2296	-169	-2997
	16	40	984	-188	-3100

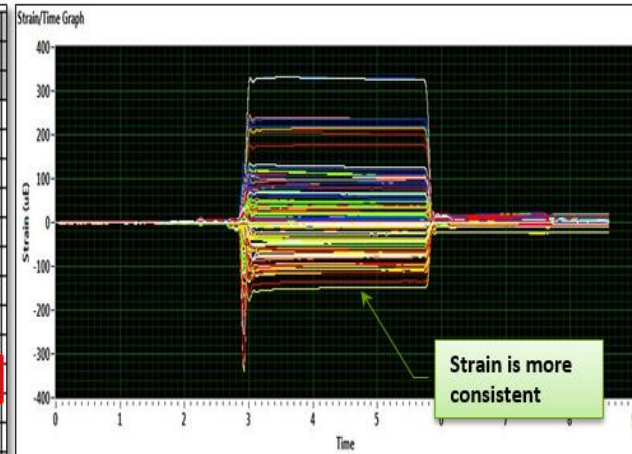



Results (Strain Rate Comparison)

- The differences in the strain rate graph is evident.
- A lot of fluctuations seen in the manual assembly.

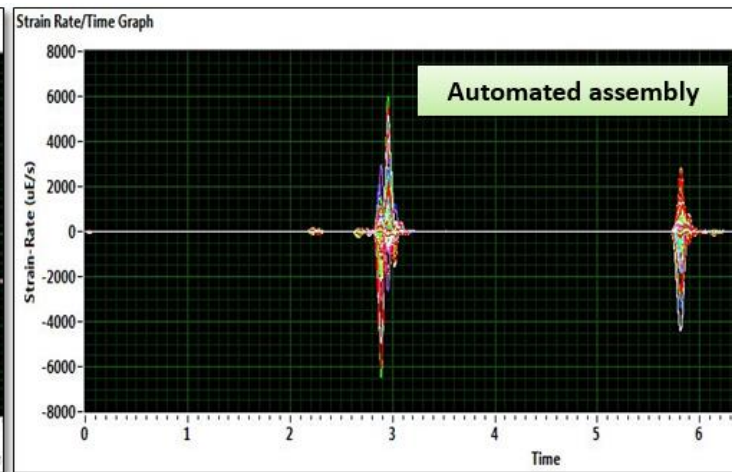
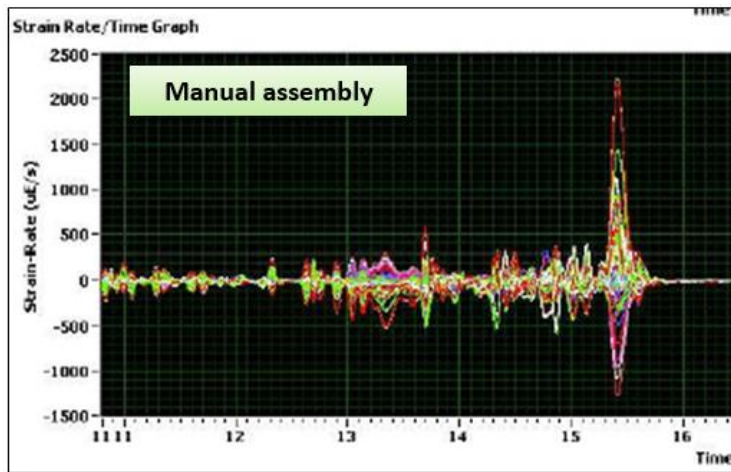



Results (FEA-Manual Assembly)

- Some differences in strain results of experiment & simulation occurred.
- Varying factors can cause this such as actual material properties, operator strength, strain gauge misplacement, or pin dimensions.
- Both lines increased until a peak strain is noted at the end.
- Plastic deformation in the snap-fit features.
- Highest strain is predicted when the push pin is about to exit the PCB hole.

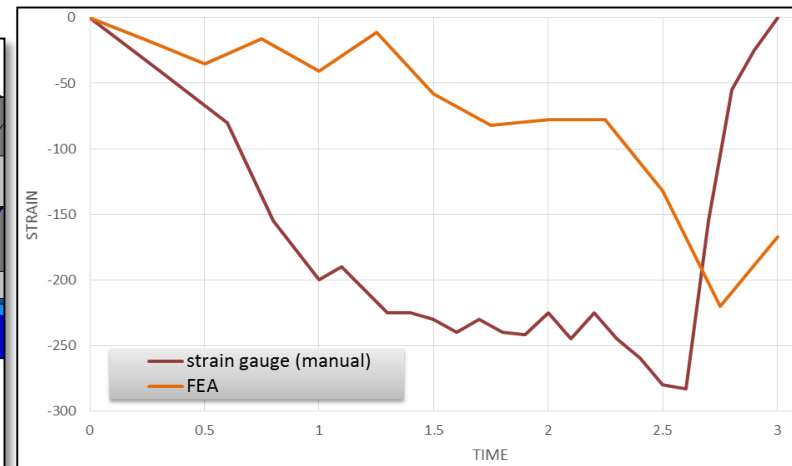
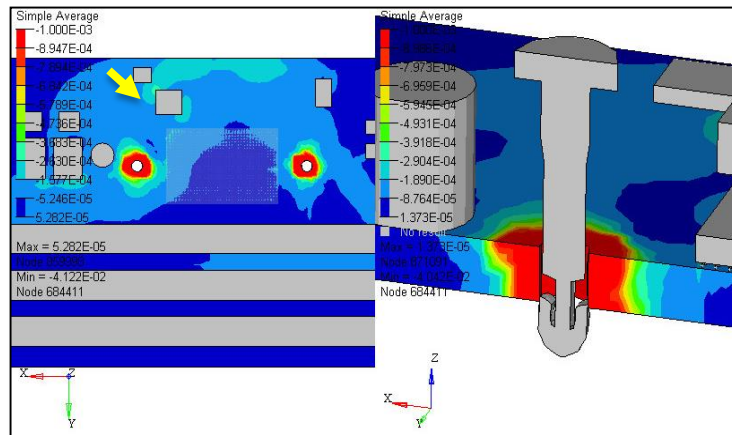



Results (FEA-Automated Assembly)

- Graph shows early peak strain and decreases into a consistent value.
- Experimental and simulation graph lines show similar trend.
- Push pin is assembled to the board at a faster rate. Strain is stable when the push metal rods maintain maximum displacement for a few seconds.
- As the pin is pushed deeper in the PCB hole, the contact area and force increases leading to the high developed strain.

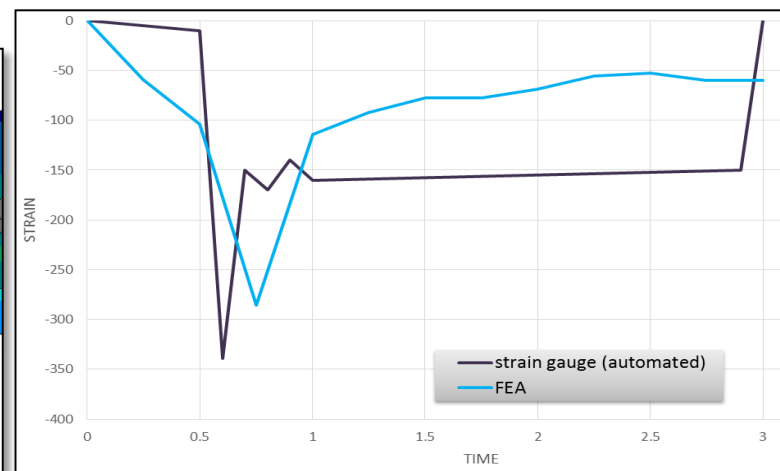
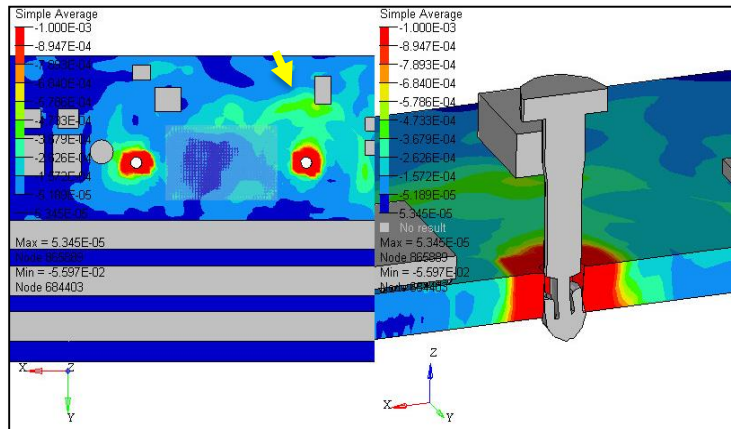



Results (Impact of BGA location)

- FE model for automated process assembly is used for reference.
 - ❑ Case 1 → Original BGA location
 - ❑ Case 2 → BGA moved in the Y axis (vertical) 1 mm away from the board edge
 - ❑ Case 3 → BGA moved in the -X axis (horizontal) direction by 1 mm
- A significant decrease in strain is observed in Case 2 while in Case 3, there was a slight increase in the predicted maximum principal strain.

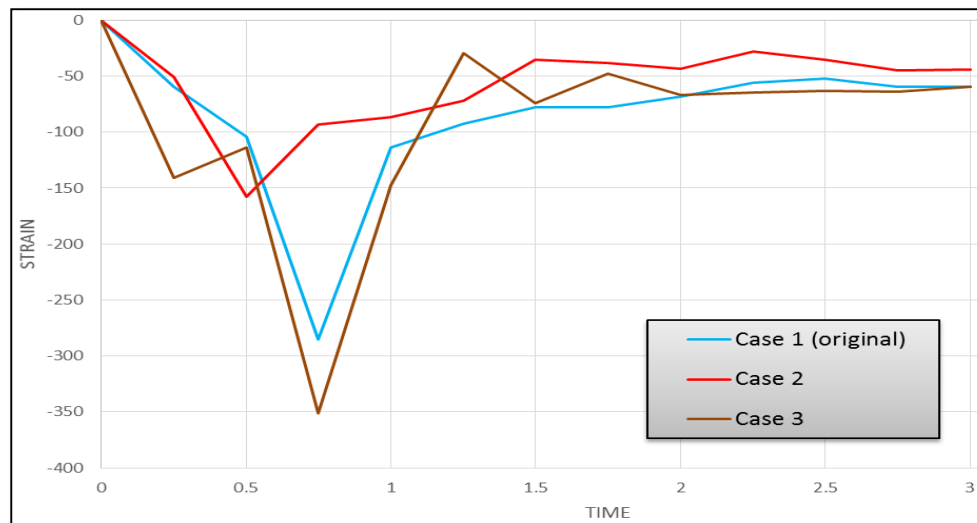



Summary

- The finite element models for FEA of a heat sink assembly by manual and automated processes have been presented in this paper.
- Based on results, automated assembly is preferred than the manual assembly process.
- After several iterations, the differences between experimental (strain gauge testing) and FE analysis results were reduced and trends were noted to achieve optimized FE models.
- These FE models can be used to perform other studies to improve strain values and avoid damaging board flexure. One such factor is the location of the BGAs on the printed circuit board.
- Further studies can help improve the FE model. Actual testing for material properties can be performed. Other factors affecting BGAs can also be included in a DOE matrix.



Thank You

